



Civil Aviation Advisory Publication

July 2011

This publication is only advisory but it gives a CASA preferred method for complying with the *Civil Aviation Regulations 1988*.

It is not the only method, but experience has shown that if you follow this method you will comply with the Civil Aviation Regulations.

Read this advice in conjunction with the appropriate regulations.

Contents

1. Welding authority - background	2
2. Grant of welding authority	2
3. How to apply	2
4. Your obligations as the holder of an aircraft welding authority	3
5. Maintaining standards	4
6. Who can apply for authorisation to conduct aircraft welding examinations?	4
7. How to apply for authorisation	4
8. Conducting an aircraft welding examination	5
APPENDIX A - CASA welding syllabus publication aircraft welding examinations	A1
APPENDIX B - Acceptable standards	B1

Aircraft Manual Welding — Approvals and Qualifications

The relevant regulations and other references

- Civil Aviation Regulations 1988 (CAR) 33C - 33I (Aircraft welding authorities).
- CAR 29A Interpretation.
- Civil Aviation Order (CAO) 100.23 Airworthiness Authorities – general.

This CAAP will be of interest to

This CAAP applies to individuals or organisations carrying out welding in the course of maintenance of Australian aircraft and those seeking authorisation or already authorised to conduct aircraft welding examinations.

This CAAP does not apply to welding performed as part of any manufacturing process described in CASR Part 21.

Why this publication was written

The purpose of this CAAP is to give information on how to apply for the initial issue or renewal of an aircraft welding authority under CAR 33D.

Status of this CAAP

This is the first revision of CAAP 33-1 first published in March 1994. The revision corrects typographical errors, adds appropriate technical standards for braze welding, removes references to redundant standards and incorporates contemporary standards. CASA has also taken the opportunity to align Australian welding requirements with those of the national aviation authorities of the Federal Aviation Administration (FAA) and the European Aviation Safety Agency (EASA).

For further information

For application and policy advice contact the Civil Aviation Safety Authority's (CASA) Airworthiness Engineering Branch on the national phone number 131 757.

1. Welding authority - background

1.1 Welding is a class of maintenance not covered by the CASR Part 66 Aircraft Maintenance Engineers licensing structure. To carry out welding work on an Australian aircraft, a person must hold a welding authority issued under CAR 33D.

1.2 Section 20AB (2) of the Civil Aviation Act 1988 prescribes a penalty of 2 years imprisonment for persons performing maintenance on an aircraft or aeronautical product if they have not been authorised under the regulations to do so.

1.3 A holder of an aircraft welding authority may only carry out those types of welding processes that are specified in the welding authority document.

1.4 Duration of welding authorities

1.4.1 Aircraft welding authorities may be granted for a period of not more than 2 years.

2. Grant of welding authority

2.1 Who is eligible?

2.1.1 An applicant for a welding authority under CAR 33D must satisfy the training and competency requirements set down by CASA. Eligibility for issue of a welding authority under CAR 33D includes those who have:

- successfully completed an Australian Quality Training Framework recognised course of practical and theoretical training in the particular type of manual welding and parent metal group qualification sought; and
- passed the applicable welding test(s) set out in the CASA Welding Syllabus (Appendix A of this CAAP).

3. How to apply

3.1 An application for a grant, renewal or addition to an aircraft welding authority can be made by completing the application *Form 352 Application for Initial Issue/Variation/Renewal of an Aircraft Welding Authority* available on the CASA website at: <http://www.casa.gov.au>.

3.2 CASA will, on accepting your application:

- allocate to you or confirm your existing Aviation Reference Number (ARN) for future reference with you;
- arrange the CASA assigned Inspector if applicable; and
- forward your application form to the person you nominated to conduct the examination who will then contact you to arrange the examination time/date/venue.

3.3 Renewal

3.3.1 The procedures for renewing a welding authority are as follows:

- In order to renew an aircraft welding authority for a further 2 years, an applicant must successfully complete the aircraft welding examinations specified in Appendix A within the 3 months preceding the application.

- Where the welder is employed in an Approved Maintenance Organisation holding a CASA approval, which includes welding of aircraft or aeronautical products, that organisation will arrange for the welder to prepare the appropriate test sample or samples. The organisation's employee who supervises the applicants preparation of weld test pieces, must be authorised to do so under CAR 29A (1) (b). The organisation will submit the samples to a National Association of Testing Authorities (NATA) approved testing organisation for examination.
- Welders who are not employed by an approved maintenance organisation must arrange for a CAR 29A (1) (b) authorised person to oversight the preparation and execution of the weld sample(s) and transportation to a NATA approved testing organisation.
- **All** holders of an aircraft welding authority endorsed with a Braze Welding permission must successfully complete a braze weld test procedure in accordance with Appendix A.

3.4 Recognition of equivalent welding qualifications

3.4.1 CASA currently recognises qualifications issued by:

- Civil Aviation Authority UK (BCAR Subsection A8-10 - Approval of Welders); or
- A welder certification issued within the preceding 2 years by a Federal Aviation Administration approved maintenance organisation whose approval includes welding of aircraft.

3.5 CASA will consider equivalent welding qualifications for the issue of an aircraft welding authority without requiring the applicant to undergo the welding training and examination if:

- the equivalent qualifications are current/valid at the time of application; and
- the applicant can provide appropriate supporting documentary evidence, such as a qualification document and authenticated associated employment records.

3.6 In the case of employer-issued certifications, CASA will require documentary evidence that the certification was assessed and issued in accordance with an appropriate standard. Acceptable standards are listed in Appendix B.

3.7 An aircraft welding authority issued under these provisions will take effect from the date of approval and will be issued for a maximum period of 2 years from the date of last issue of the welding qualification document that is being recognised.

3.8 Welding Authorities issued may be renewed as per CAO 100.23.

4. Your obligations as the holder of an aircraft welding authority

4.1 Welding authority – maintenance performance scope

4.1.1 You can only carry out the kind of welding that is specified on your aircraft welding authority and only in accordance with CAR 2A approved maintenance data.

4.2 Certification

4.2.1 Under the requirements of CAR 42ZE, you must certify the completion of the welding you carried out in the documents kept for recording such maintenance.

4.2.2 Separate certification for the completion of maintenance on an aircraft must be made by an appropriately rated licensed aircraft maintenance engineer. The Licensed Aircraft Maintenance Engineer (LAME) certification signifies that the maintenance (manual welding) has been carried out in accordance with approved maintenance data by a suitably qualified person and that the LAME is satisfied that the aircraft is fit for return to service.

4.3 Notification of your name or address changes

4.3.1 You should notify CASA within 14 days, of any changes in your name, business address or correspondence addresses to ensure that CASA's records are accurately maintained.

5. Maintaining standards

5.1 Competency

5.1.1 CASA may at any time require a welding authority holder to undergo welding tests in order to ascertain the person's competency as a welder.

5.1.2 If you do not achieve a satisfactory standard your authorisation may be suspended wholly or in part until such time as you successfully pass the appropriate weld tests.

5.2 Charges and costs

5.2.1 You are responsible for the supply of all materials and equipment, the charges for the person conducting the aircraft welding examination and the costs for the welding test assessment by the weld testing agency.

6. Who can apply for authorisation to conduct aircraft welding examinations?

6.1 Eligibility

6.1.1 If you wish to conduct aircraft welding examinations you need demonstrated understanding and working knowledge of the welding examination requirements, the associated civil aviation regulatory requirements, responsibilities of a welding authority holder and:

- have experience as a welding lecturer at a recognised welding training organisation, e.g., TAFE college/approved training school, or
- have experience as a welding supervisor in an approved welding organisation, or
- hold other appropriate engineering qualifications and background acceptable to CASA.

7. How to apply for authorisation

7.1 How to Apply for Examiner Approval

7.1.1 You should prepare a written application and send it together with the prescribed fees to the CASA Service Centre as per the approved form. The application should include:

- your personal details, qualifications and experience details; and
- any documentary evidence necessary to support your claims.

7.1.2 CASA will assess your capabilities to conduct the aircraft welding examinations by taking into account your application details, the facilities and equipment available to you and the assurance that you will continue to receive all information necessary for the conduct of the welding examinations.

7.2 Instrument of Appointment

7.2.1 If your appointment is approved, you will be issued with an *Instrument of Appointment*. The Instrument of Appointment will contain a Schedule that sets out the conditions attached to exercising your authorisation.

- Your appointment as an authorised person is valid for a period of two years unless otherwise specified in the Instrument of Appointment or revoked by CASA.
- You must establish and maintain a system for the retention and control of records and documentation relating to the examination conducted.
- You must notify CASA as soon as practicable if you change your name or address.

7.2.2 If your appointment expires, or is about to expire and you wish to continue as an authorised person, then you should apply to CASA. This should be done preferably before the actual expiry date.

7.2.3 Your application should be accompanied by the appropriate fee and your re-appointment will be subject to:

- satisfactory performance of the functions and activities authorised over the period of validity; and
- possible CASA inspection of processed applications and records.

7.2.4 If your application is approved, you will be issued with a new Instrument of Appointment and identity card.

8. Conducting an aircraft welding examination

8.1 Aircraft welding examinations are conducted in accordance with conditions specified in the Schedule attached to the Instrument of Appointment and this CAAP. The following is representative of the nature of the conditions that would be specified in the Schedule:

8.2 Examination Preparation and conduct

8.2.1 Immediately on receiving an application form you should arrange a suitable examination date/time/venue with the applicant.

8.2.2 When you are conducting aircraft welding examinations you should ensure:

- the applicant has a demonstrated knowledge of a welder's responsibility and limitations as the holder of an aircraft welding authority, and has adequate knowledge of welding terms and definitions as set out in *Australian Standard-AS2812*, the interpretation of drawings, joint preparation and welding defects and thermal stress;
- each aircraft welding examination is carried out in accordance with the specifications set out in this CAAP;
- the welding positions and metal groups are as specified and the procedures and consumable materials are representative of those used in production;
- the metal selected satisfies a degree of difficulty similar to the welding characteristics of the production welding task, any pre and/or post weld heat treatment, if required, is performed in a similar manner to that required for production welds represented by the weld samples; and
- the welds are not dressed or sand-blasted after welding, and any weld residue (flux, slag) is removed in the normal manner from the weld samples.

8.3 Inspection of Welds

8.3.1 On completion of each welding examination, you should inspect the weld for obvious defects. If any defects are found, you may permit the applicant to attempt a further examination. Note that, if applicants are not satisfied with the quality of a weld during an examination, they may attempt a further welding examination at their own discretion.

8.4 Weld Identification and Documentation

8.4.1 On conclusion of the examination, you should stamp, etch or permanently mark the applicant's Aviation Reference Number (ARN) and the welding position codes (as applicable) on each welding sample.

8.4.2 You should then complete the Request For Weld Test form (available on the CASA website as Form353.pdf) and send the form, together with the welding samples to the appropriate weld testing agency for weld assessment.

8.4.3 After receiving the weld testing agency's assessment report, you should enter the relevant details onto the original application form and certify for the conduct of the examination.

8.5 Failed Examination Action

8.5.1 Where applicants fail an aircraft welding examination, they may make arrangements to attempt a further examination without penalty. However, if they again fail the re-examination, CASA recommends that they should complete some form of remedial training and give you a practical demonstration of the type of welding process/metal group before they are permitted to re-attempt the examination.

8.6 Reporting Examination Completion

8.6.1 On completion of the examination, you should make and retain copies of all documentation and send the originals of the application form and the weld testing agency report as per the guidance to the CASA administratively responsible for the application.

8.7 Documenting activities

8.7.1 You should record all activities dealing with the conduct of the examinations and keep copies of all documents as specified in the Schedule of Conditions attached to the Instrument of Appointment. You will be required to provide access to all documentation and records to CASA officers when requested.

APPENDIX A –**CASA WELDING SYLLABUS PUBLICATION
AIRCRAFT WELDING EXAMINATIONS****CONTENTS**

General	A2
Types of manual welding	A2
Parent metal groups	A2
Definitions	A2
PART 1 - AIRCRAFT WELDING EXAMINATIONS	
Types of aircraft welding examinations	A3
Examinations required for initial grant of an aircraft welding authority	A3
Examinations required for renewal of an aircraft welding authority	A3
Welding authority renewals and additions – general information	A4
Examination failure	A5
Parent metal thickness limitation/conditions	A5
Welding identification and welding position code	A6
Examples of examination combinations and conditions	A6
Aircraft Welding Examination No. 1 – Joint 1	A9
Aircraft Welding Examination No. 2 – Joint 2	A10
Aircraft Welding Examination No. 3 – Joint 3	A11
Aircraft Welding Examination No. 4 – Joint 4	A12
Aircraft Welding Examination No. 5 – Joint 5	A13
PART 2 - EXAMINATION ASSESSMENT CONSIDERATIONS	
Assessment standard	A14
Braze welding assessment	A14
Visual examination	A14
Tensile tests	A15
Bend test	A16
Metallographic examination	A17
Weld Assessments — Figures 1 - 5	A19
Welding Assessments — Figures 6 - 10	A20

General

This publication sets out the requirements necessary for the preparation and assessment of aircraft welding examinations required by CAR 33D, 33G and 33H.

Types of manual welding

Satisfactory completion of aircraft welding examinations, made under one of the following types of manual welding processes, qualifies the welder with respect to that type of welding:

- Difficulty rating:
 - Type 1 - Gas welding.
 - Type 2 - Braze welding. [Note limitations apply].
 - Type 3 - Manual Metal Arc Welding.
 - Type 4 - Gas Tungsten Arc Welding (GTAW - TIG).
 - Type 5 - Gas Metal Arc Welding (GMAW - MIG).
 - Type 6 - Plasma Arc Welding (PAW).

Parent metal groups

- The parent metal groups for which qualifications may be obtained are:
 - Group 1 - Aluminium Alloys.
 - Group 2 - Magnesium Alloys.
 - Group 3 - Carbon Steels and Low Alloy Steels.
 - Group 4 - Corrosion and Heat Resisting Steels.
 - Group 5 - Nickel Alloys.
 - Group 6 - Copper based Alloys.
 - Group 7 - Titanium Alloys.

Definitions

- All terms and definitions used in this publication are in accordance with Australian Standard (AS) AS 2812 – 2005 — “Welding, brazing and cutting of welds — Glossary of terms”.
- ‘Tubular part’, means a part of a primary structure not exceeding approximately 50 mm in diameter.

PART 1 – AIRCRAFT WELDING EXAMINATIONS

Types of aircraft welding examinations

Dependent on the welding qualification sought, the aircraft welding examinations required to obtain qualifications are to be prepared as follows:

- Joint No. 1 - Sheet to sheet butt weld as specified in Diagram 1.
- Joint No. 2 - Tube to sheet fillet weld as specified in Diagram 2.
- Joint No. 3 - Sheet to sheet fillet weld as specified in Diagram 3.
- Joint No. 4 - Tube to tube test weld as specified in Diagram 4.
- Joint No. 5 - An aircraft part typical of the most difficult to be welded in production/repair by the applicant, e.g. repair/rebuild of engine nozzle guide vane; repair of gas turbine engine flame tube or repairs to component castings etc.

Note: A welding test joint which simulates the Joint No. 5 part may be prepared by the applicant at the discretion of the person conducting the aircraft welding examination. Where a simulated joint is prepared, the applicant must use the same materials, equipment, process, joint configuration, welding technique and maintenance data/specifications as that used for the production or repair part.

Examinations required for initial grant of an aircraft welding authority

For the purposes of CAR 33C and 33D, an applicant for the grant of an aircraft welding authority, must satisfactorily complete at least one of the aircraft welding examinations set out in this publication. The aircraft welding examination must be completed in each of the types of manual welding and parent metal groups to which the application relates and is relevant to the conditions of the authorisation sought.

Applicants for a braze welding type of manual welding qualification must satisfactorily complete at least the aircraft welding examination Joint No. 2 in the parent metal group to which the application relates.

Braze welding is restricted to tube-to-sheet Joint No. 2 and the type of weld joint prepared as Joint No. 5. There is no ‘unrestricted’ qualification or ‘restricted to exclude tubular parts’ qualification permitted for braze welding.

Note: Refer to CAR 29A for types of manual welding and parent metal groups, CAR 33C for the application for an aircraft welding authority and CAR 33D for the grant of an authority.

Examinations required for renewal of an aircraft welding authority

For the purposes of CAR 33G, the holder of an aircraft welding authority seeking renewal of the authority must, within the 3 month application period, satisfactorily complete aircraft welding examinations, as set out in this publication, that CASA considers necessary in the interests of the safety of air navigation.

Failure to satisfactorily complete the necessary renewal welding examinations before the expiry of an aircraft welding authority will result in the holder having to complete all the appropriate welding examinations required for the initial issue of the particular welding authorisations held.

Welding authority renewals and additions – general information

Renewal requirements for holders of an aircraft welding authority not employed as a full time aircraft welder in a CASA approved organisation

The holder of an aircraft welding authority who has **not** been employed in a CASA approved organisation as a full time aircraft welder, who is seeking renewal of the authority must, within the 3 month application period, satisfactorily complete:

- one Joint No. 1 in each parent metal group endorsement in any ‘arc’ welding process;
- one Joint No. 1 in each parent metal group endorsement in the ‘gas’ welding process (if applicable); and
- where an ‘unrestricted’ endorsement is held, one Joint No. 4 in the most technically difficult welding type and metal group qualification held.

Renewal requirements for holders of an aircraft welding authority employed as a full time aircraft welder in a CASA Approved Organisation

The holder of an aircraft welding authority employed as a full-time welder in a CASA approved organisation, is required to successfully complete the same aircraft welding examinations as that for an independent aircraft welding authority holder.

However, the employer (Certificate of Approval holder) may implement and document procedures in the organisation’s quality control system/procedures manual whereby similar (renewal) welding examinations are carried out over the duration of the welding authority’s 2 year validity period and analysed either in-house (where the organisation has suitable/necessary testing equipment) or at a NATA accredited testing facility.

Where the employer implements procedures for examinations to be carried out and analysed in-house, the holder of the aircraft welding authority employed as a full-time welder must successfully complete, at least:

- one Joint No. 1 in the most technically difficult welding type and metal group qualification held; and (where applicable)
- for holders of an ‘unrestricted’ endorsement, one Joint No. 4 in the most technically difficult welding type and metal group qualification held.

Such tests may form part of the employer procedures but are to be conducted within the 3 month renewal application period mutually convenient to the organisation and CASA.

Most technically difficult welding type and metal group

Unless previously determined in respect of a particular applicant, determination of the most technically difficult welding type and metal group for the purpose of these tests must be made by a person holding the necessary metallurgical or engineering qualifications or a CAR 35 approval holder.

Renewal requirements for holders of aircraft welding authority endorsed with Braze Welding

All holders of aircraft welding authority endorsed with Type 2 — Braze Welding qualifications must, within the 3 month application period, satisfactorily complete a welding examination in accordance with a Standard acceptable to CASA.

Note: Refer CAR 33F for duration of an aircraft welding authority and CAR 33G for renewal examinations required for the approval of additional type of manual welding or parent metal group.

Addition of a type of manual welding

For the purposes of CAR 33H, if the holder of an aircraft welding authority is seeking to have a type of manual welding (other than Type 2 — Braze Welding) added to the authority, the holder must satisfactorily complete at least one of the aircraft welding examinations, set out in this publication, in the type of manual welding to which the application relates in any parent metal group.

Addition of a parent metal group

For the purposes of CAR 33H, if the holder of an aircraft welding authority is seeking to have a parent metal group added to the authority, the holder must satisfactorily complete at least one of the aircraft welding examinations, set out in this publication, in the parent metal group to which the application relates in any type of manual welding.

Addition of Braze Welding

If the holder of an aircraft welding authority is seeking to have Type 2 — Braze Welding added to the authority, the holder must satisfactorily complete a braze welding test in accordance with a standard acceptable to CASA

[Refer CAR 33H for changes to an aircraft welding authority]

Examination failure

For the purposes of CAR 33D, 33G and 33H, if an applicant fails a welding examination for the initial issue, renewal or additional qualifications of a welding authority, the applicant may submit a further welding examination sample for assessment.

If the applicant then fails the re-examination, CASA recommends that the applicant completes some form of remedial practical and theoretical training on the type of manual welding and parent metal group and demonstrate welding practice to the person conducting the welding examination prior to further examination.

Documentary evidence may be required by the person conducting the re-examination in support of any remedial welding training completed.

Parent metal thickness limitation/conditions

The welding examinations — Joints No. 1, No. 2, No. 3 and No. 4 specify that the weld must be carried out on a pre-determined representative parent metal thickness for the particular welding process (gas) or (arc).

Welders complying with the examination metal thickness specifications are authorised to carry out manual welding (using the particular process) on parent metals of any thickness. There will be no parent metal thickness limitation or condition endorsement made on the welding authority.

Welders who carry out welding examinations using parent metals of a greater thickness than that specified for the welding examination will be authorised to carry out welds on the parent metal of that thickness or greater. The welding authority will be endorsed with a parent metal thickness condition e.g., if the welding examination specifies that the sheets to be arc welded must be 1.2 mm thick and the welder uses sheets of 1.5 mm thick, then the parent metal thickness condition endorsed on the welding authority will limit the welder to only carrying out welds on metals of 1.5 mm thickness or greater.

Welding identification and welding position code

On completion of the welding examination, the person conducting the examination must stamp, etch or permanently mark each welding examination sample with the applicant's ARN and the appropriate welding position code letter, as follows:

- F – Flat (fillet or butt), where the face of the weld is approximately horizontal;
- H – Horizontal (fillet or butt), where the line of weld root is approximately horizontal;
- OH – Overhead (fillet or butt), where the weld is performed from the under-side of the joint;
- HV – Multiple Position (fillet only), where the axis of the tube is approximately horizontal and the tube is not rotated during welding; or
- V – Vertical (fillet or butt), where the line of the weld root is approximately vertical.

Examples of examination combinations and conditions

An aircraft welding authority will be granted subject to the qualification conditions or restrictions determined by the type and number of welding examination combinations selected and satisfactorily completed by the welder.

Examples of the conditions CASA may impose when particular aircraft welding examination combinations have been successfully completed are given below and apply to both the initial issue and additional qualification requirements for an aircraft welding authority:

Example #1

Welding Examination Carried Out
Joint No. 1
Condition Entered on Welding Authority — for each type of manual welding and parent metal group
“Restricted to Butt welds of ‘X’ mm thick sheets”

This example is intended to show the flexibility of welding examination selection for welding authorisation whereby an applicant only requires one welding examination qualification. The satisfactory completion of Joint No. 1 will authorise the welder to carry out manual welding ‘butt welds’ (using a particular process) on sheets of a specified thickness (for a particular parent metal). Similarly, if, for example, a Joint No. 3 is selected and satisfactorily completed, the form of condition entered on the authority may read “Restricted to fillet welds of sheets ‘x’ mm thickness” (for the particular process/metal group).

Example #2

Welding Examinations Carried Out	
Joint No. 2	Joint No. 5
Condition Entered on Welding Authority — for each parent metal group	
“Braze Welding only - Restricted to particular parts or types of parts” (statement may include description of part(s) or approved procedures reference)	

With respect to Braze welding, the braze welding qualification is restricted for tube to sheet Joint No. 2 and the type of the weld prepared as Joint No. 5. There is no “Unrestricted” qualification or “Restricted to exclude tubular parts” qualification permitted for braze welding.

Example #3

Welding Examinations Carried Out	
Joint No. 1	Joint No. 5
Condition entered on Welding Authority — for each type of manual welding and parent metal group	
“Restricted to the particular parts or types of parts” (Statement may include description of part or approved welding procedures reference)	

The annotation “Restricted to particular parts or type of parts”, requiring Joints No. 1 and 5, applies where the only welds to be carried out are restricted to a particular joint configuration on a specific part or types of parts, e.g., repair/rebuild of engine nozzle guide vanes, or repair of gas turbine engine flame tube or repairs to component castings, etc. This may also apply where welds are carried out repetitively on a production line basis in accordance with particular procedural data.

The holder is only authorised to carry out manual welding of the particular part or type of parts described in the welding authority (e.g., butt joints in flame tubes of (type) engines, or edge welds on nozzle guide vane support Part No. ..., etc.).

The welding carried out must be as specified in the approved maintenance data for the parent metal group and type of manual welding for which the “Restricted to part” annotation is granted.

Example #4

Welding Examinations Carried Out		
Joint No. 1	Joint No. 3	Joint No. 5
Condition Entered on Welding Authority — for each type of manual welding and parent metal group		
“Restricted to exclude Tubular Parts”		

The annotation “Restricted to exclude tubular parts”, requiring Joints No. 1, 3 and 5 is intended to make provision for applications for metal groups other than aluminium or steel, which are generally not used in tubular form in aircraft primary structure or are not generally available in tubular form. e.g., magnesium, nickel or titanium (as a tubular part is part of a primary aircraft structure not exceeding approximately 50 millimetres in diameter, then an exhaust manifold is not considered a tubular part since it is not primary structure).

The holder is authorised to carry out manual welding of any part (e.g., flat, horizontal and overhead butt welds and fillet welds for sheet-to-sheet), except for tubular parts, where welding is specified in approved maintenance data for the parent metal group and type of manual welding for which the “Restricted” annotation is granted.

Example #5

Welding Examinations Carried Out		
Joint No. 1	Joint No. 2	Joint No. 4
Condition Entered on Welding Authority — for each type of manual welding and parent metal group		
“Unrestricted” or “Nil”		

The “Unrestricted or Nil” annotation, requiring Joints No. 1, 2 and 4 is granted on the basis that the selection of joints is considered sufficiently searching of welding ability in the majority of cases (e.g., flat, horizontal, overhead, vertical and multi-position butt welds [sheet-to-sheet], fillet welds [sheet-to-sheet] [sheet-to-tube] and fillet and butt welds [tubular parts]).

It is intended to apply primarily to aluminium and steel metal groups and where structural tubing is in common use. Where more difficult welds are to be carried out to satisfy production, additional Joint No. 5 examination may be required.

The welder is authorised to carry out manual welds of any part where welding is specified in approved maintenance data, without restriction for the parent metal group and type of manual welding for which the “Unrestricted or Nil” annotation is granted.

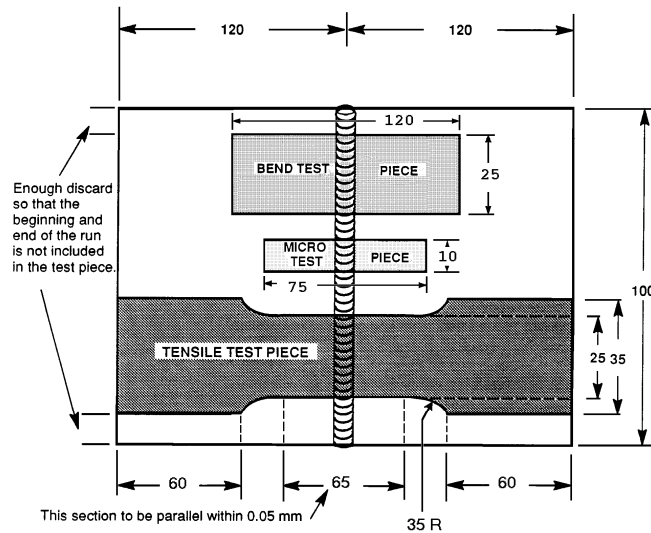
AIRCRAFT WELDING EXAMINATION No. 1 – JOINT 1**Diagram 1 – Joint No 1 – Sheet to Sheet Butt Weld****Weld for aircraft welding examination No. 1**

- For the purposes of undertaking the aircraft welding examination No. 1, a person must carry out a Joint No. 1 - sheet to sheet butt weld in accordance with the specifications set out in diagram 1.
- All measurements are nominal and in millimetres (mm).
- The examinations must be carried out using parent metals of the same alloy type or grade procured to the applicable specifications referenced in the production procedure/maintenance data.
- For oxy-acetylene (gas), GTAW (TIG) and MTAW (MIG) welding processes, examination metal thickness of sheets is 1.6 mm thick (this will include material of 0.063 inch thickness).
- For other arc welding processes, examination metal thickness of sheets is 2.5 mm to 2.6 mm thick (this includes sheet of 0.100 inch thickness).
- If sheets of other thicknesses are used, the thicknesses of the sheets should be kept in these proportions. (Note: authorisation will be subject to thickness conditions.)
- Tack welds may be made from any position but shall be incorporated into the completed weld.
- Welding position - flat.
- The weld shall be performed by welding from one side only using correct filler rod, flux or shielding gas as applicable.
- The sheets to be welded shall be supported so that they do not contact the bench or other material that will form a backing bar in the welded joint.
- Completed welds may be cleaned by wire brush, but must not be dressed, hammered or sand blasted (light tapping with a hammer to remove scale deposits is not regarded as a dressing operation).
- Weld residue (flux, slag) shall be removed from the weld in the usual way.
- Be aware of any grain direction in the material which may compromise the bend test.

Note: The welding examination sample must be submitted to the Weld Testing Agency intact. The testing agency is responsible for the preparation of the particular test pieces.

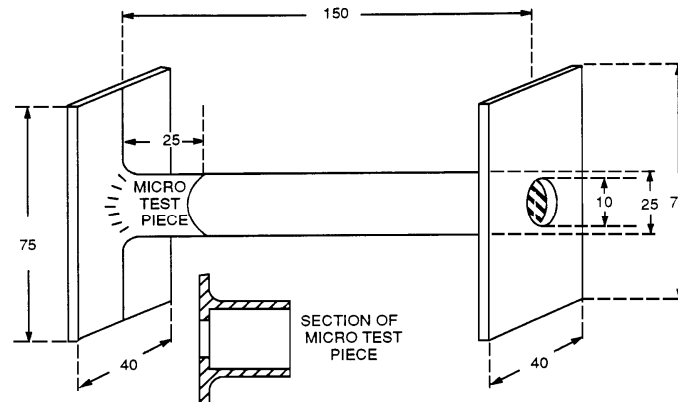
AIRCRAFT WELDING EXAMINATION No. 2 – JOINT 2**Diagram 2 – Joint No 2 Sheet to Tube Fillet Weld****Weld for aircraft welding examination No. 2**

- For the purposes of undertaking the aircraft welding examination No. 2, a person must carry out a Joint No. 2 - sheet to tube fillet weld in accordance with the specifications set out in diagram No. 2.
- All measurements are nominal and in millimetres (mm).
- The examinations must be carried out using parent metals of the same alloy type or grade procured to the applicable specifications referenced in the production procedure/maintenance data.
- For oxy-acetylene (gas), GMAW (MIG) and GTAW (TIG) welding processes, examination metal thickness for tube is 0.9 mm wall thickness and end plates of 1.6 mm thick.
- For other arc welding processes, examination metal thickness for tube is 1.6 mm to 1.65 mm (this includes 0.065 inch) wall thickness and end plates of 2.5 mm to 2.6 mm thick (includes 0.100 inch sheet).
- If tubes and end plates of other thicknesses are used, the thicknesses should be kept in these proportions. (Note: authorisation will be subject to thickness conditions)
- Where a greater thickness material is used there must be two nominal gauge sizes difference between the tube and end plate.
- Centre of end plates to be drilled with 10 mm diameter hole prior to welding.
- End plates may be positioned by tack welds.
- The first weld shall be completed by working around the tube with the end plate horizontal (flat) on the work surface and the tube in the vertical position.
- The second weld shall be completed by working under and over the tube with the tube in the horizontal position (as depicted in diagram 2) and not moved during the process of completing the weld. (Note: the micro test piece will be taken from the second weld area).
- Completed welds may be cleaned by wire brush, but must not be dressed, hammered or sand-blasted (light tapping with a hammer to remove scale deposits is acceptable and is not regarded as a dressing operation).
- Weld residue (flux, slag) shall be removed from the weld in the usual way.

Note: The welding examination sample must be submitted to the Weld Testing Agency intact. The testing agency is responsible for the preparation of the particular test pieces.

AIRCRAFT WELDING EXAMINATION No. 3 – JOINT 3

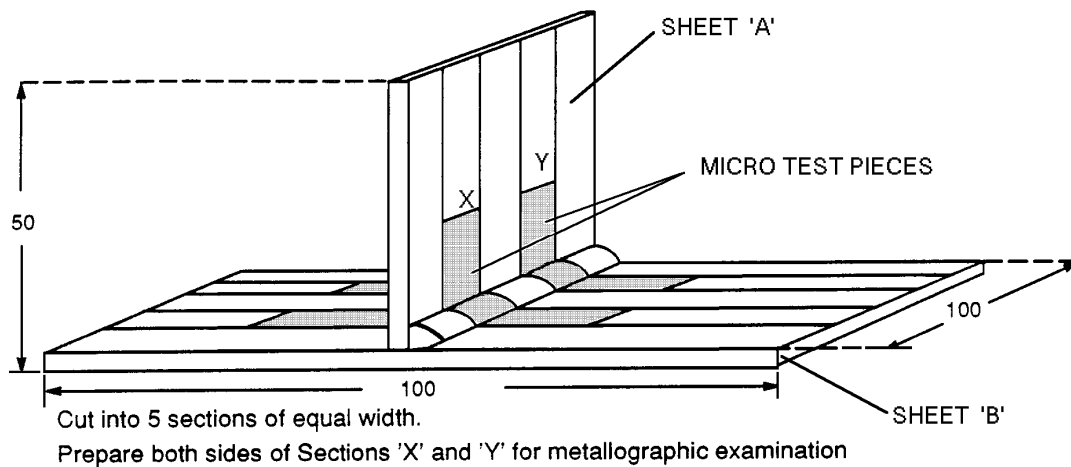
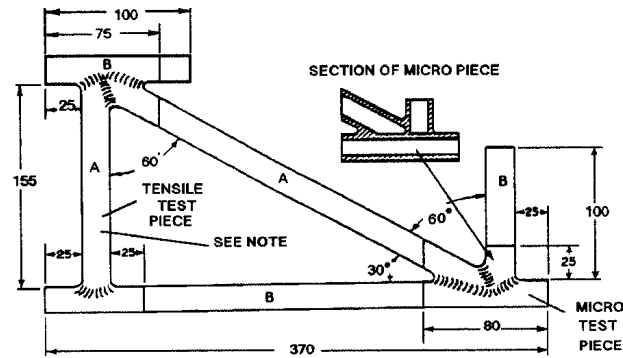

Diagram 3 – Joint No 3 – Sheet to Sheet Fillet Weld

Weld for aircraft welding examination No. 3

- For the purpose of undertaking the aircraft welding examination No. 3, a person must carry out two Joint No. 3 - sheet to sheet fillet welds in accordance with the specifications set out in diagram 3.
- All measurements are nominal and in millimetres (mm).
- The examinations must be carried out using parent metals of the same alloy type or grade procured to the applicable specifications referenced in the production procedure/maintenance data.
- Examination metal thickness for both arc and gas welding processes are: Sheet 'A' - 1.2 mm to 1.3mm (includes 0.50 inch sheet) and Sheet 'B' - 1.6 mm (includes 0.063 inch sheet).
- If sheets of other thicknesses are used, Sheet B must be two nominal gauge sizes (for the selected material) greater than Sheet A (Note: authorisation will be subject to thickness conditions).
- The plates should be positioned by tack welds on the opposite side to the weld and one weld shall be welded with Sheet 'A' in the vertical (as depicted in diagram 3).
- The second weld shall be with the weld joint in the overhead position.
- Completed welds may be cleaned with a wire brush but must not be dressed, hammered or sand-blasted (light tapping with a hammer to remove scale deposits is acceptable and is not regarded as a dressing operation).
- Weld residue (flux, slag) shall be removed from the weld in the usual way.

Note: The welding examination sample must be submitted to the Weld Testing Agency intact. The testing agency is responsible for the preparation of the particular test pieces.

AIRCRAFT WELDING EXAMINATION No. 4 – JOINT 4**Diagram 4 – Joint No 4 – Tube To Tube Weld**

Note: Vent holes should not be drilled in the tensile test piece vertical tube 'A'.

Weld for aircraft welding examination No. 4

- For the purposes of undertaking the aircraft welding examination No. 4, a person must carry out a Joint No. 4 - tube to tube weld in accordance with the specifications set out in diagram No. 4.
- All measurements are nominal and in millimetres (mm).
- The examinations must be carried out using parent metals of the same alloy type or grade procured to the applicable specifications referenced in the production procedure/maintenance data.
- Each tube has a diameter of 19 mm to 19.5 mm (includes 0.750 inch OD tube). Examination metal thicknesses for oxy-acetylene (gas), GMAW (MIG) and GTAW (TIG) welding processes are: Tubes 'A' - 0.9 mm (includes 0.35 inch) wall thickness and Tubes 'B' - 1.4 mm to 1.5 mm (includes 0.58 inch) wall thickness.
- For other arc welding processes the examination metal wall thickness is 1.6 mm to 1.65 mm (includes 0.065 inch walled tube) for Tubes "A" and 2.0 mm to 2.15 mm (includes 0.083 inch wall tube) for Tubes "B".
- If tubes of other thicknesses are used, then Tubes "B" must be two nominal gauge sizes greater (for the selected material) than Tubes "A". (Note: authorisation will be subject to thickness conditions).
- The tubes shall be prepared assembled (in the manner shown in diagram No. 4) in a jig and tacked. The assembly is then to be removed from the jig and mounted in a vertical position with the longest tube horizontal and at the lowest point (as depicted in diagram 4). The assembly shall not be moved from this position during the process of completing the welds.
- The uppermost joint which is formed by the short horizontal, vertical and diagonal tubes shall be welded by the overhead technique and the remaining joints completed by working around the joints.
- Completed welds may be cleaned by wire brush, but must not be dressed, hammered or sand blasted (light tapping with a hammer to remove scale deposits is not regarded as a dressing operation)
- Weld residue (flux, slag) shall be removed from the welds in the usual way.

Note: The welding examination sample must be submitted to the Weld Testing Agency intact. The testing agency is responsible for the preparation of the particular test pieces.

**AIRCRAFT WELDING EXAMINATION No. 5 – JOINT 5 —
PRODUCTION/REPAIR PART WELD**

Weld for aircraft welding examination No. 5

- For the purposes of undertaking the aircraft welding examination No. 5; using the procedures, joint configuration, welding positions, equipment and consumables specified for the production or repair weld, a person must carry out a weld on:
- an aircraft part that is no longer intended for use in an aircraft or as a part of an aircraft; or
- a simulated aircraft part made of a metal of a type and grade that is the same as that metal to be used for the production or repair part.

Note: The welding examination sample must be submitted to the Weld Testing Agency intact. The testing agency is responsible for the preparation of the particular test pieces.

PART 2 – EXAMINATION ASSESSMENT CONSIDERATIONS

Assessment standard

Under the provisions of CAR 33D, 33G and 33H, for the grant, renewal or change of an aircraft welding authority CASA must be satisfied that an applicant has passed the aircraft welding examinations considered necessary in the interest of the safety of air navigation. Fundamental to passing an aircraft welding examination is the satisfactory assessment of the completed weld and welded joint.

To ensure that standardisation is maintained nationally, assessments of the aircraft welding examinations are to be conducted by an organisation accredited by the NATA Australia to test metal welds.

Assessment of the weld is to be based on consideration of the entire test sample including visual examination, metallographic examination and mechanical tests where relevant. Where doubt exists as to the acceptability of a sample, or if it is thought that a defect may be of a local nature, further sections should be examined and the assessment of the sample based on all the sections examined. Where a joint sample does not meet the stated criteria in **one** assessment area, then the complete joint must be repeated and re-assessed.

Braze welding assessment

Braze welds must be inspected and tested in accordance with procedures, standards and limitations as set out in an industry standard acceptable to CASA Refer to Appendix of this CAAP for acceptable standards

Fusion welding assessment

The assessments required for each aircraft welding examination joint sample are as follows:

- Joint No. 1 – Sheet to Sheet Butt Weld: Visual Examination; Bend Test (AS 2205.3.1); Tensile Test (AS 2205.2.1); and Metallographic Test (AS 2205.5.1).
- Joint No. 2 – Tube to Sheet Fillet Weld: Visual Examination and Metallographic Test (AS 2205.5.1).
- Joint No. 3 – Sheet to Sheet Fillet Weld: Visual Examination and Metallographic Test (AS 2205.5.1).
- Joint No. 4 – Tube to Tube Weld: Visual Examination; Tensile Test (AS 2205.2.1) and Metallographic Test (AS 2205.5.1).
- Joint No. 5 – Aircraft Part or Part Typical of Production Weld: Visual Examination and Metallographic Test (AS 2205.5.1).

Visual examination

The entire weld is to be examined. Inspection should be performed at magnification of up to 3 times for welds in parent metal up to 1.6 mm and without magnification for thicker metals.

Features to be Examined

The contour and weld dimensions should be examined for the following features:

- The transition from the surface of the parent metal to the weld face is to have a reasonably smooth blended contour, free from excessive undercut or an abrupt edge to the reinforcement at the toe of the weld. Some undercut in parent metal thicknesses of 1.6 mm and above is acceptable where it does not exceed the following amounts, 0.05T or 0.08 mm whichever is the lesser for butt welds and 0.1T or 1.6 mm whichever is the lesser for fillet welds.
- The weld face should be reasonably smooth, free from cavities and other surface defects. The ripple pattern should be regular, and the depth 'B' (Figure 2) of occasional depressions is not to exceed 0.15T, where 'T' is the thickness of the thinner parent metal. The weld and adjacent parent metal should be free from excessive weld spatter.
- The weld width 'W' (Figures 1 and 2), should be reasonably uniform, and for butt welds the weld width is to be the minimum necessary for the weld metal to penetrate the joint as specified below.
- For butt welds the joint should have complete penetration evidenced by a penetration bead (Figure 1), or the absence of an unfused joint line at the root of the weld (Figure 3).
- Butt weld reinforcement 'R' (Figure 1) is to be present and should preferably be approximately 0.3T, but should not exceed 0.5T.
- For external corner welds, the actual throat thickness 'A' (Figure 10) is to be not less than 'T', weld width 'W' and reinforcement 'R' should be the minimum necessary to obtain complete penetration of the joint as evidenced by a penetration bead or the absence of an unfused joint line at the inside corner.
- The presence and extent of warping or misalignment.
- The presence of hard spots or cracking caused by stray arc strikes adjacent to, or on the weld.

Unacceptable Welds

Welds which exhibit any type of crack, incomplete joint penetration, underfill or overlap and stray arc strikes made on the parent metal in a position adjacent to or other than the weld preparation are unacceptable.

Tensile tests

Method of Test

The tensile test pieces shown in Joints No. 1 and No. 4, (Diagrams 1 and 4 of Part 1) are to be cut from the sample. Test the piece to destruction in accordance with the procedure specified in AS 2205.2.1 - Transverse Butt Tensile Test. Note that for the Joint No. 4 tensile test piece, the intent of the AS 2205.2.1 procedure should be used. Light filing of the internal surface is permitted to obtain a neat fit for this test. The ultimate tensile stress (calculated on the minimum cross-sectional area of the sample neglecting the weld) and the position of the failure should be recorded.

Tensile Test Assessment

For the Joint No. 1 tensile test, the weld is satisfactory if the test piece fails in the parent metal outside of the heat affected zone (HAZ) as determined by the micro test piece. If failure occurs at the toe of the weld or in the weld metal, the weld is satisfactory only if the fracture surfaces are free of defects (such as cracking, large pores, lack of fusion, excessive porosity or inclusions etc.), and the weld conforms to all other requirements and the ultimate tensile strength (UTS) is at least 90% of the strength of the parent metal. If any doubt exists as to the value of the UTS, it is recommended that a hardness test be conducted to accurately determine the UTS. This may be necessary if the failure in the parent metal occurs at less than 90% of the published UTS value for a given material. The UTS for a given material will have a range of values, if the material falls into the lower range of values, the UTS will also be lower. For the Joint No. 4 tensile test, the test piece must fail in the parent metal, outside of the HAZ as determined by the micro test piece. Failure in any other area is cause for rejection.

Bend test

Method of Test

The bend test piece (Diagram 1 of Part 1) is to be cut from the sample and tested with the weld lying along the centre line of the bend with the weld face (the side from which the welding was performed) on the outside of the bend in accordance with the procedure specified in AS 2205.3.1 - Transverse Guided Bend Test Method. The test piece is to be dressed on both sides e.g., by filing or grinding, so that the weld metal is flush with parent metal. The edges of the test piece should be given a reasonable radius. Bending is to be carried out by the application of continuous pressure.

Extent of Bend Tests

The test sample is to withstand bending through an angle of 180° over a radius of twice the nominal thickness, 'T', of the test sample without breaking or developing a crack visible to the unaided eye, except for the material listed in the following table and where the material specification for the parent metal specifies a less severe bend.

Material	Angle of Bend (degrees)	Radius of Bend
Magnesium Alloys	180	10T
Aluminium Alloys containing more than 6% Mg	180	5T
Aluminium Alloys of the 6061-6063 Type	180	8T
Cr-Mo Steels of the 4130 Type*	90	4T
Titanium Alloys		
Tensile Strength Less than:		
516 Mpa	180	3T
516-827 Mpa	180	5T
827-965 Mpa	180	8T
965-1069 Mpa	180	10T
1069-1171 Mpa	180	14T

Material	Angle of Bend (degrees)	Radius of Bend
Martensitic and PH Stainless	Not applicable	
Steels and PH Nickel Alloys		
* After any pre or post-weld heat treatments similar to production welds represented by the test samples.		

Metallographic examination

Method of Test

The metallographic (macro) tests are to be carried out in accordance with the procedure specified in AS 2205.5.1 - Macro Test - Cross Section Examination Method. Sections are to be taken from each test sample at the following locations and prepared for metallographic examination as follows:

- Joints No. 1 to 4: At the approximate locations shown in the relevant joint sketches (Diagrams 1 to 4 of Part 1).
- Joint No. 5: At appropriate locations to cover each type of joint in the weldment.

An additional sample should be prepared and examined if doubt exists as to the acceptability of the sample. The sections are to be taken transverse to the direction of welding at locations where the weld quality appears poorest, except that the start and finish sections of the sheet samples should be avoided.

Weld Assessment Criteria

The sections should be examined unetched and etched at magnification of up to 5 times and where appropriate, reported in accordance with the following requirements:

- The depth of fusion of fillet welds 'F' (Figures 4 to 7) shall be at least $0.15T$, where 'T' is the thickness of the thinner parent metal.
- The size of fillet welds 'S' (Figures 4 and 5) are to be not less than the following values, where 'T' is the thickness of the thinner parent metal:

Parent Metal Thickness (mm)	Minimum Weld Size
0.254 - 0.635	2.4T
0.660 - 1.270	1.6T
1.295 - 2.285	1.3T
2.310 - 3.175	1.1T
3.200 and over	T

- The design throat thickness of fillet welds 'D' (Figure 4) should not be less than $0.7x$ the minimum weld size 'S' as specified above.
- In fillet welds some lack of complete root fusion is acceptable where the following conditions exist. In all other cases complete root fusion is required.
- For welds of approximately 45° included angle, the unfused distance 'X' (Figure 6) should not be greater than $1/3$ of the distance 'Y'.
- For welds of approximately 30° included angle, the presence of a cavity and an unfused section is permissible provided that the throat thickness 'D' is not less than the minimum weld size 'S' specified above (Figure 7).

- For welds of 90° in sheets or tubes where the base metal thickness is equal to or less than 1.6 mm incomplete root fusion of either weld leg for a distance 'X' of not more than 0.3 times actual throat size 'D' is acceptable (Figure 8) provided that the actual throat thickness is not less than the minimum weld size 'S' specified above.
- For lap welds the actual throat thickness 'A' (Figure 9) and the weld size 'S' should be not less than 'T'; depth of fusion 'F' should be not less than 0.15T.

Unacceptable Weld Features

Welds which exhibit any of the following defects are unacceptable.

- Cracks.
- Incomplete fusion at the weld face except for the cases stated above.
- Undercut in excess of the amounts stated in the visual examination.
- Overlap.
- In fillet welds a ratio of the leg of the larger size to the leg of the smaller size of greater than 1.5 at any cross section.
- A leg length more than 6T or T + 4.5 mm whichever is the lesser for fillet welds in parent metal thicknesses equal to or less than 1.6 mm (where members differ in thickness 'T' are to be based on the thinner member).
- In convex fillet welds a convexity in excess of 0.1 times the average weld leg length at any location.
- In concave fillet welds, an actual throat size of less than 0.5T at any cross section. Where members differ in thickness 'T' are to be based on the thinner member.
- Excess penetration at the tube or sheet face opposite the weld bead in fillet welds of more than 1.6 mm thickness. In thickness up to and including 1.6 mm, excess penetration may extend for a distance of not more than the tube or sheet thickness 'T' beyond the tube or sheet wall.
- An individual pore size of 0.4T or 2.5 mm whichever is the lesser (where members differ in thickness 'T' is to be the thickness of the thinner member).
- Excessive porosity. Inclusions such as Tungsten shall be counted as porosity. All defects less than 0.05 mm size in parent metal thicknesses, up to 1.6 mm and less than 0.12 mm or 0.03T size, whichever is the lesser in parent metal thicknesses above 1.6 mm, are to be disregarded. Where porosity or the maximum pore size appears excessive, the weld is to be sectioned at other locations or broken open (nick-break) and a length of the weld examined. The assessment is to be based on the weld length of all metallographic sections.
- Any other defects which are attributable to unsatisfactory welding techniques or any unsatisfactory knowledge of welding consumables or the parent metals used.

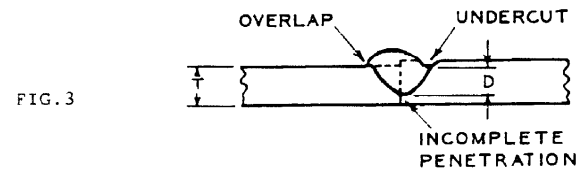
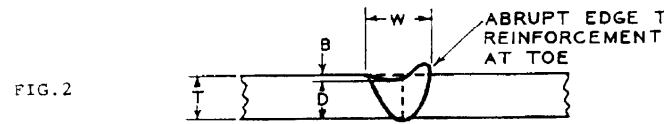
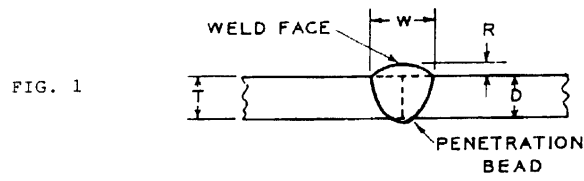

B = DEPRESSION DEPTH
 D = DESIGN THROAT THICKNESS
 R = REINFORCEMENT
 T = THICKNESS OF THE THINNER PARENT METAL
 W = WELD WIDTH

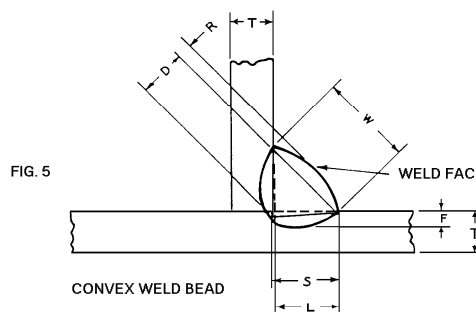
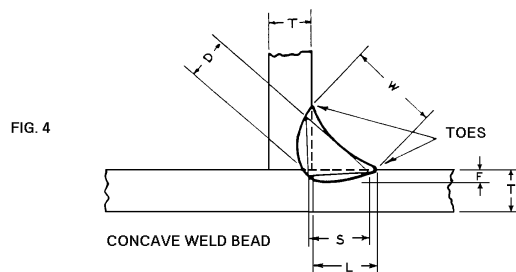

D = DESIGN THROAT THICKNESS
 F = FUSION DEPTH - MAXIMUM
 L = LEG LENGTH
 R = REINFORCEMENT
 S = SIZE OF WELD
 T = THICKNESS OF THE THINNER PARENT METAL
 W = WELD WIDTH

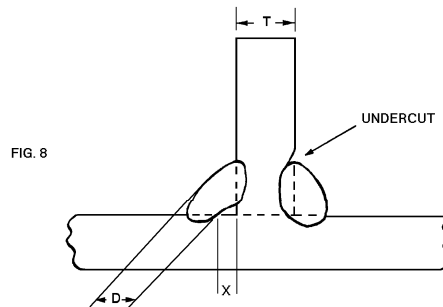
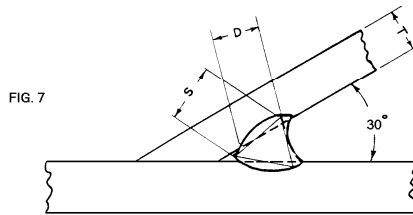
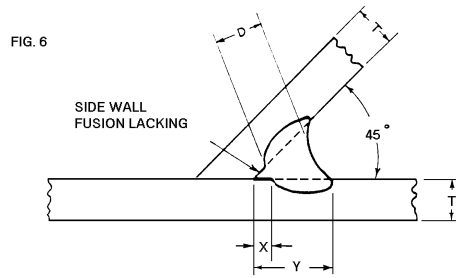

D = DESIGN THROAT THICKNESS
 T = THICKNESS OF THE THINNER PARENT METAL
 S = SIZE OF WELD

$S \min = T$
 $A \min = T$
 $F \min = 0.15T$

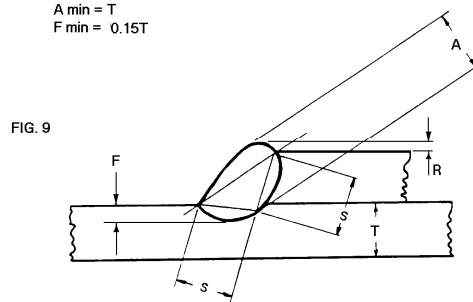

$A \min = T$

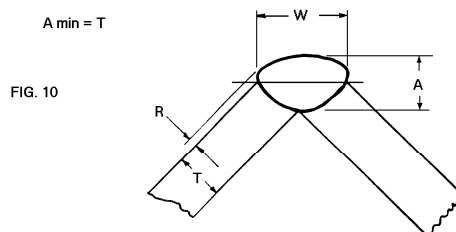

A = ACTUAL THROAT THICKNESS
 F = DEPTH OF FUSION - MAXIMUM
 R = REINFORCEMENT
 S = SIZE OF WELD
 W = WELD WIDTH

APPENDIX B –**ACCEPTABLE STANDARDS**

AS/NZS 3992 – Welding and brazing qualification.

AWS B2.1 – Specification for Welding procedure and Performance Qualification.

AWS B2.2 – Specification for Brazing Procedure and Performance Qualification.

AWS C3.4 – Specification for Torch Brazing.

AWS D17.1 – Specification for Fusion Welding for Aerospace Applications.

INTENTIONALLY LEFT BLANK